

# Respirable Dust Cyclone

Validated for a 4  $\mu\text{m}$  cut-point

- **Small and lightweight**
  - Only 2.6 x 1.5 inches (6.6 x 3.8 cm)
- **Aluminum construction eliminates adverse electrostatic effects**
- **Meets ACGIH/ISO/CEN respirable curve**  
Flow rate: 2.5 L/min (nominal  $D_{50} = 4.0 \mu\text{m}$ )\*
- **Provides a 3.5  $\mu\text{m}$  50% cut-point at 2.8 L/min†**
- **Specified in NIOSH Method 7500 for silica and NIOSH 0600 for respirable particulates**
- **Used with an open-face 3-piece cassette for even more particle deposition on the filter**
  - Available in 25 or 37 mm
  - Insert into middle ring

Note:  $D_{50} = 50\%$  sampling efficiency or 50% cut-point

## The SKC Aluminum Cyclone

The SKC Aluminum Cyclone is a lightweight respirable dust sampler that is used with a filter loaded into a three-piece filter cassette. The cyclone separates dust particles according to size. The respirable particles collect on a filter for analysis while larger particles fall into the grit pot and are discarded.

The ACGIH, NIOSH, International Organization for Standards, and European Standard Committee (ISO/CEN) specify a collection efficiency curve with a median cut-point at 4.0  $\mu\text{m}$ . When performing respirable dust sampling with cyclones, it is important to adjust the flow rate to give the closest possible match over the whole curve (not just at a single point). The ACGIH/ISO/CEN curve requires using the flow rate that minimizes the bias of the cyclone separation from this curve.

New York University Medical Center, a leading aerosol research organization, has calibrated the SKC Aluminum Cyclone and the results were carefully evaluated for bias over the whole curve, showing that 2.5 L/min\* most closely matches the curve. The SKC Aluminum Cyclone meets the ACGIH/ISO/CEN curve at 2.5 L/min as specified in NIOSH Method 0600. The cyclone can also be operated at 2.8 L/min for alternate applications

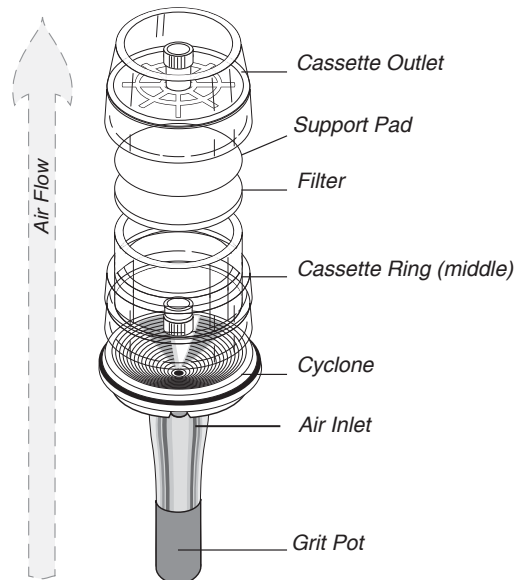

Exploded view of cyclone-filter cassette assembly

\* As previously published, a 2.6 L/min flow rate will give a 4  $\mu\text{m}$  cut-point, however, 2.5 L/min will give a better match over the entire curve. Contact SKC Inc. for a copy of the calibration report on the SKC Aluminum Cyclone.

† Determined using experimental data obtained at flows from 2.0 to 4.0 L/min

at a 3.5  $\mu\text{m}$  cut-point. The SKC Aluminum Cyclone is also specified in NIOSH Method 7500 for Silica and NIOSH Method 0600 for Particulates Not Otherwise Regulated.

The SKC Aluminum Cyclone is available in two sizes: 25 mm for use with 25-mm three-piece cassettes and 37 mm for use with 37-mm three-piece cassettes. The filter material, pore size, and support pad must be selected as specified by the sampling method used.

A cyclone's collecting efficiency may be influenced by electrostatic effects. If the cyclone carries a net charge, particles of the same charge will be repelled by the cyclone and will not be sampled efficiently. SKC cyclones are constructed of conductive materials that eliminate the static problem associated with nylon (non-conductive) cyclones.



# Respirable Dust Cyclone

Validated for a 4 µm cut-point

## Operation

The SKC Aluminum Cyclone is used with a three-piece filter cassette, a filter cassette holder, and a constant flow personal sampling pump such as one of the SKC Universal XR Series samplers.

A representative weighed filter with a support pad is placed into a three-piece cassette (with inlet section removed) and attached to the cyclone. The cyclone-cassette assembly is then attached to the filter cassette holder. The pump with the cyclone-cassette assembly in line is calibrated with a primary standard calibrator such as the Defender Calibrator Cat. No. 717 Series. The grit pot remains on the cyclone during calibration and sampling.

The cyclone is clipped to a worker's collar or pocket as close to the breathing zone as possible. The pump is clipped to the worker's belt or placed in a protective pouch. The pump is activated and the worker wears the apparatus during the entire sampling period.

After sampling, the filter cassette is removed, sealed, and sent with all data to a laboratory for analysis.

## Calibration Chamber

The aluminum calibration chamber fits over the stem of both the 25 and 37-mm cyclones and allows standard Tygon® tubing to be attached for calibrating the airflow.

## Holder for 25 and 37-mm Cassettes

The lightweight filter cassette holder is designed to attach to a worker's collar and will accommodate either 25-mm cassettes with cowl or two or three-part 37-mm cassettes with or without a cyclone.



SKC Aluminum Cyclone



Cyclone-cassette assembly  
in filter cassette holder  
accessory



Calibration Chamber

## Cyclones

Named for the rotation of air within its chamber, the cyclone is a particle size selector for sampling airborne particulates. It functions on the same principle as a centrifuge: the rapid circulation of air separates particles according to their equivalent aerodynamic diameter with the respirable particles collecting on the filter while the larger particles fall into the grit pot to be discarded. The cyclone/filter assembly is attached to a worker's collar near the breathing zone.

## Respirable Dust and Sampling Efficiency Curves

Respirable dust refers to particles that settle deep within the lungs that are not ejected by exhaling, coughing, or expulsion by mucus. Since these particles are not collected with 100% efficiency by the lungs, respirable dust is defined in terms of sampling efficiency curves. These curves are sometimes referred to in terms of the 50% sampling efficiency or cut-point at a certain flow rate.

## Performance Profile

<b>Sample Time:</b>	Varies
<b>Sample Rate:</b>	2.5 L/min for 4-µm cut-point* 2.8 L/min for 3.5-µm cut-point†
<b>Sample Pump:</b>	Universal XR or AirChek Series
<b>Sample Media:</b>	25 or 37-mm filters in 3-piece cassettes
<b>Tubing:</b>	1/4-inch ID

\* As previously published, a flow rate of 2.6 L/min will yield a 4-µm 50% cut-point, however, a 2.5 L/min flow rate will provide a better match over the entire curve.

† Determined using experimental data obtained at flows from 2.0 to 4.0 L/min

## Ordering Information

Description		Cat. No.
Aluminum Cyclone‡	25 mm	225-01-01
	37 mm	225-01-02
Filter Cassette Holder for 25 and 37-mm cyclones		225-1
Calibration Chamber for 25 and 37-mm cyclones		225-01-03
Three-piece Filter Cassettes	25 mm	225-3-25LF
	37 mm	225-3LF
Replacement Grit Pot, pk/25		P225011

‡ Three-piece cassettes are required for use with SKC Aluminum Cyclones.

**For more information on the SKC Aluminum Cyclone, request SKC Technical Note, Publication No. 1519.**

## SKC Limited Warranty and Return Policy

SKC products are subject to the SKC Limited Warranty and Return Policy, which provides SKC's sole liability and the buyer's exclusive remedy. To view the complete SKC Limited Warranty and Return Policy, go to <http://www.skcinc.com/warranty.asp>.

