

# **Research Report**

## **Validation of Styrene using SKC Passive Sampler 575-002**

### **Abstract**

A sampling method for Styrene in air has been validated for concentration levels from 5 to 250 ppm and for exposure times from 7.5 minutes to 12 hours. The 575-002 passive sampler used has a sample medium of Anasorb® 747. Desorption was with carbon disulfide and analysis by gas chromatography with flame ionization detection.

The analytical recovery over the range of 25 ppm for 8 hours to 250 ppm for 4 hours (0.68 to 3.3 mg) was variable but >75%. A desorption efficiency correction curve should be used to correct analytical results. There was no effect of humidity on recovery.

The sampling rate is 13.7 ml/min which was confirmed by the precision and accuracy calculations using 100 results (see Background; Sampling Rate Determination). Samples can be taken from 10°C to 40° C.

Minimum recommended sampling time is 15 minutes. Maximum recommended sampling time is 8 hours.

Samples were stable for up to three weeks when stored at room temperature or in a refrigerator.

A full validation of Styrene was done according to NIOSH Protocol.<sup>1</sup>

Two samplers were validated simultaneously. The 575-002 sampler has greater capacity, and can be used where more volatile compounds (e.g. acetone) are present. The 575-003 has the better recovery and is therefore more useful at low concentrations or for measuring STELs. The 575-003 should not be used to sample compounds with boiling points below that of Styrene.

### **Authors**

Daniel L. Fiorito  
Martin Harper

Compiled by Martin Harper, Ph.D.

**SKC Inc.**  
**863 Valley View Road**  
**Eighty Four, PA 15330 USA**

# Importance of Validation of Passive Samplers

There are distinct differences between a passive sampler and a sample tube.

The most important difference is that a passive sampler does not have a foolproof back up section that guarantees that all the chemical hazard has been collected and there is a true and total measure of the worker exposure.

Secondly, the sorbent media is exposed to the external environment and this poses problems not associated with a sample tube where the air sample passes into the sample tube directly contacting the sorbent media. That is why it is critical to use a strong sorbent medium in passive samplers to assure complete capture and retention.

Therefore, for compliance purposes a passive sampler must be laboratory tested and validated under worst case field conditions for all factors that affect sampling accuracy as well as interaction between affects.

NIOSH has laid out a rigorous and complete validation protocol to assure that the sample collected is a complete and true measure of worker exposure. The following are the factors that the NIOSH protocol addresses:

## Factors That Affect Complete Sample Uptake & Retention

Chemical Hazard Concentration	Temperature
Time of Exposure	Humidity
Sorbent Capacity	Interfering Chemicals
Sorbent Strength	Reverse Diffusion from Sorbent Surface
Wind Velocity	Sampler Orientation
Interaction of Any of the Above Factors	

Validation by NIOSH protocol assures that the sample results are a true and total measure of worker exposure.

**SKC Validation follows the NIOSH Validation Protocol.  
Certain experiments may have been modified for practical  
reasons, or to provide more rigorous tests.**

## User Responsibility

The sampler manager should be a professional trained in air sampling and aware of the limitations and advantages of the method being used. It is also very helpful if they have a working relationship with the analytical techniques being used and the requirements of record keeping.

In accordance with ASTM D6346-98 and ANSI 104-1998 standards, use of samplers outside the range of conditions used in these validation tests does not assure accurate results and is not recommended. It is the user's responsibility to determine whether the conditions of the sampling site fall within the range tested. For bi-level validations it can be assumed that the applicable range is that used for testing the lower member of the homologous series.

Workers should be trained in the use of the equipment. In collecting the sample, care should be taken in the location of the sampler on the worker. It is to be openly exposed near the breathing zone. Exact times of exposure must be recorded. No moisture condensation should occur on the sampler. Workers should not be allowed to touch the sampler as they may transfer contamination. Particular attention must be paid to environments where liquid aerosols may be present, since droplets of liquid solvent on the sampler face will invalidate the sample. Any other field conditions outside of the limits used in the NIOSH protocol, such as extreme temperatures or stagnant air conditions which might affect the sampler operation should be recorded.

Good laboratory practice must be followed. Follow the operating instructions for the desorption time needed for complete desorption. Use only the correct desorption instrument. If gas chromatography is used as the analysis method, base line separation should occur with the chemical hazard of interest and proper instrument calibration procedures used.

NIOSH or OSHA analytical methods should be used.

# Summary of NIOSH Validation Protocol<sup>1</sup>

Characteristic	Experimental Design	Interpretation of Results														
<b>1. Analytical Recovery</b>	Spike 16 samplers, 4 at each of 4 concentration levels (0.1, 0.5, 1.0 & 2.0 x STD) Equilibrate about 12 h and analyze.	For the higher 3 levels require $\geq 75\%$ recoveries with $S_r \leq 0.1$ .														
<b>2. Sampling Rate and Capacity</b>	Expose samplers (4 per time period) for 1/8, 1/4, 1/2, 1, 2, 4, 6, 8, 10 & 12 h to 2 x STD, 80% RH and 20 cm/s face velocity. Plot concentration vs. time exposed. Determine MRST and SRST.	Verify sampling rate. State useful range at 80% RH & 2 x STD. Capacity - sample loading corresponding to the downward break in conc. vs time curve from constant concentration. SRST - time linear uptake rate achieved. MRST-0.67 x capacity (1 analyte) MRST-0.33 x capacity (Multi-analyte)														
<b>3. Reverse Diffusion</b>	Expose 20 samplers to 2 x STD. 80% RH for 0.5 x MRST. Remove and analyze 10 samplers. Expose others to 80% RH and no analyte for remainder of MRST.	Require $\leq 10\%$ difference between means of the two sampler sets at the 95% CL.														
<b>4. Storage Stability</b>	Expose 3 sets of samplers (10 per set) at 80% RH, 1 x STD, and 0.5 x MRST. Analyze first set within 1 day, second set after 2 weeks storage at about 25° C, third set after 2 weeks storage at about 5° C.	Require $\leq 10\%$ difference at the 95% CL between means of stored sampler sets and set analyzed within 1 day.														
<b>5. Factor Effects</b>	Test the following factors at the levels shown. Use a 16 -run fractional factorial design (4 samplers per exposure) to determine significant factors.	Indicate any factor that causes a statistically significant difference in recovery at the 95% CL. Investigate further to characterize its effect.														
	<table border="0"> <thead> <tr> <th><u>Factor</u></th> <th><u>Test Levels</u></th> </tr> </thead> <tbody> <tr> <td>analyte concentration</td> <td>0.1 &amp; 2 x STD</td> </tr> <tr> <td>exposure time</td> <td>SRST &amp; MRST</td> </tr> <tr> <td>face velocity</td> <td>10 &amp; 150 cm/s</td> </tr> <tr> <td>relative humidity</td> <td>10 &amp; 80% RH</td> </tr> <tr> <td>interferant</td> <td>0 &amp; 1 x STD</td> </tr> <tr> <td>sampler orientation</td> <td>parallel &amp; perpendicular (to air flow)</td> </tr> </tbody> </table>	<u>Factor</u>	<u>Test Levels</u>	analyte concentration	0.1 & 2 x STD	exposure time	SRST & MRST	face velocity	10 & 150 cm/s	relative humidity	10 & 80% RH	interferant	0 & 1 x STD	sampler orientation	parallel & perpendicular (to air flow)	
<u>Factor</u>	<u>Test Levels</u>															
analyte concentration	0.1 & 2 x STD															
exposure time	SRST & MRST															
face velocity	10 & 150 cm/s															
relative humidity	10 & 80% RH															
interferant	0 & 1 x STD															
sampler orientation	parallel & perpendicular (to air flow)															
<b>6. Temperature Effects</b>	Expose samplers (10 per temp) to 0.5 x STD at 10, 25, & 40° C for 0.5 x MRST	Define temperature effect and verify correction factor, if provided.														
<b>7. Accuracy and Precision</b>	Calculate precision and bias for samplers (10 per conc. level) exposed to 0.1, 0.5, 1 & 2 x STD at 80% RH for $\geq$ MRST. Use data from previous experiments.	Require bias within $\pm 25\%$ of true value at 95% CL with precision $S_r \leq 10.5\%$ for 0.5, 1, & 2 x STD levels.														

## Summary of NIOSH Validation Protocol (cont.)

Characteristic	Experimental Design	Interpretation of Results
<b>8. Shelf Life</b>	Observe samplers throughout evaluation for changes in blank values, physical appearance, etc. Test samplers from more than one lot, if possible.	Note shelf storage time at which changes begin to occur. Indicate whether correctable or not.
<b>9. Behavior in the Field</b>	Consider problems not predictable from laboratory experiments.	Record temperature, humidity, air velocity, other contaminants, etc.
<i>Area Sampling:</i>	Expose passive samplers and independent method samplers (13 each) to the same environment.	Calculate precision and bias. Compare with laboratory results.
<i>Personal Sampling:</i>	Conduct personal sampling with $\geq 25$ sampler pairs. Place pairs of passive samplers and independent samplers on the same lapel of each worker.	Calculate bias. Compare with area sampling and laboratory results

## **Bi-Level Validation (previously designated by SKC as 5B)**

Validation of passive samplers is essential to ensure accurate determination of airborne chemical levels. To assist manufacturers and users, the National Institute for Occupational Safety and Health (NIOSH), the Health and Safety Executive (HSE)<sup>2</sup>, and the Comité Européen de Normalisation (CEN)<sup>3,4</sup> have developed comprehensive protocols for the validation of passive samplers.

Bi-level validation can also be used to assure a sample that gives the total and complete exposure to a chemical hazard.

Bi-level validation is only for a series of chemically related compounds, i.e., members of a homologous series. Bi-level validation includes a full protocol validation on key compounds followed by a partial validation on other members of the series.

The concept of a bi-level validation of chemically related compounds for a given sorbent and sampler design is based on the following premises and has been studied by Guild et al.<sup>5</sup>

1. Full validation by NIOSH, HSE, or CEN Protocol of a lower member of the series is essential to assure accurate, routine sampling under all field conditions without the need for error-corrective measures.
2. Capacity and retentivity are directly related to the affinity of a sorbent for a specific chemical. For a series of chemically related compounds, the affinity of a sorbent for a particular member compound will increase with the molecular weight and boiling point of the member. If a sorbent is suitable for collecting a low molecular weight member of the series, it will be suitable for the higher molecular weight members of the series as well.
3. For chemically stable compounds, sample loss by reverse diffusion and loss during storage are inversely related to the affinity of the sorbent for the adsorbate. Therefore, compounds with higher molecular weights and boiling points will exhibit less loss by reverse diffusion and storage. Again, if a sorbent is suitable for a member with a lower molecular weight and boiling point, it will be suitable for the higher members.
4. The linearity of uptake with time is also a function of sorbent affinity and capacity. Uptake becomes increasingly linear as the molecular weight and boiling point increases and the sample load decreases. (Protocol validation requires study of concentrations ranging from 0.1 to 2.0 x the permissible exposure limit.)

## Bi-Level Validation (cont.)

5. Temperature affects the accuracy of passive samplers in two different ways; the relation of temperature to adsorption affinity and the relation of the molecular diffusion of the sample to the sampler.
  - a. It is well known that the affinity of a sorbent for a chemical decreases with increasing temperature. If the sorbent has adequate affinity for a low molecular weight member of the series at 40° C (the maximum temperature tested under protocol), it will also be adequate at lower temperatures, and for higher molecular weight members of the series.
  - b. The effects of temperature on sample uptake follow established mathematical relationships and are not significant compared to other random sampling errors.
6. The effects of humidity because of competition or modification of sorbent affinity will be most pronounced for lower members of the series.
7. Adsorption affinity decreases with the mass adsorbed. Therefore, the “key” member chosen for full validation should have a high PEL relative to the other members of the series.
8. Air velocity and sampler-orientation effects are functions of sampler design and will be similar for all compounds.
9. If all the factors affecting sampling accuracy improve with increasing molecular weight and boiling point and there are no interacting effects of these parameters with a lower member of the series, then there will be no interacting effects with higher members.
10. The accuracy of a sampler is determined by its bias and precision. For most passive samplers, the bias is the result of the deviation of the calculated sample rate from the actual rate. By determining the sample rate under known conditions at 1 PEL, the bias is reduced to zero. Therefore, measured sample rates should be determined for all compounds.
11. The precision of a sampler is a function of the consistency of sampler manufacture and the analytical procedures in the laboratory.
12. Analytical recovery tends to decrease with increased sorbent affinity and is a function of the chemical compound, the concentration, and the sorbent. Therefore, analytical recovery should be determined for every compound over the concentration range of 0.1 to 2.0 PEL, as recommended by protocol.

**Conclusion:** The above premises have been verified, peer reviewed and published.<sup>5</sup> Therefore, Bi-Level validation (5B) is an excellent way to assure accurate performance of a passive sampler for higher members of a homologous series.

## **Comments on the Relationship Between the NIOSH and CEN Diffusive Sampler Evaluation Protocols**

The Comité Européen de Normalisation (CEN) is engaged in writing standards for air sampling equipment which include the limitations on precision and accuracy (EN 482) and the required performance tests. In the case of passive samplers the relevant performance test standard is yet to be published, but draft copies are available (prEN 838).

The precision and accuracy requirements in EN 482 are based on the use that will be made of the results, principally either for problem identification or compliance purposes. The standard for compliance purposes is a combined precision and accuracy of less than 30%, which is a looser standard than the 25% in the NIOSH protocol.

The performance tests are closely related to those in the NIOSH protocol, as might be expected, since they are trying to confirm the performance of the samplers over a similar range of environmental conditions. As in the NIOSH protocol there are tests for desorption efficiency, uptake rate at different concentrations and for different time-periods, reverse diffusion, storage stability, wind velocity and orientation, humidity, temperature, and the presence or absence of interferences. As in the NIOSH protocol these factors are normally tested using a "high" and a "low" measure, whether alone or in combination. Since there is little difference between workplace conditions in the U.S.A. and Europe, these "high" and "low" conditions are very similar in the two protocols. In general, the NIOSH test provides the more stringent conditions (e.g. 7.5 minutes up to 12 hours in the NIOSH uptake rate experiment versus 30 minutes and 8 hours in the CEN equivalent). In addition, for the majority of the experiments, the NIOSH protocol requires more samples to be taken for each data point (typically 10 rather than 6). The reverse diffusion test is one test that might be considered significantly different, and a paper showing that the results of the tests are actually comparable has been submitted for publication.<sup>6</sup>

In addition, the CEN protocol requires tests for shelf-life and packaging integrity that have been carried out for one analyte (n-Hexane) only. The 575 Series passive sampler successfully passed these tests.

For the reasons given above, SKC considers the validations presented in these research reports to be at least sufficient to meet the requirements of the European Standards prEN 838 and EN 482 for compliance monitoring. This conclusion is supported by a detailed comparison which has been submitted for publication.<sup>7</sup>

The CEN protocol supports the Bi-level theory of validation.



## SHELF-LIFE STUDY ON 575 SERIES PASSIVE SAMPLERS

**Protocol:** 4 expired and 2 unexpired 575-001 samplers were exposed to an atmosphere 100 ppm n-Hexane (2 X PEL) at 80% relative humidity (25° C) for 30 minutes, and then analyzed. Study was conducted August 1995.

### Results:

Calculated atmosphere concentration:	106 ppm
Gas sample analysis concentration:	102 ppm (RSD = 7.0%)
Sorbent tube analysis concentration:	115 ppm (RSD = 3.2%)
Sampler analysis concentration: <sup>◇</sup>	
Sampler expired 12/92:	106 ppm
Sampler expired 4/94:	106 ppm
Sampler expired 10/94:	108 ppm
Sampler expired 10/94:	110 ppm
Sampler unexpired (7/96):	100 ppm
Sampler unexpired (7/96):	100 ppm

<sup>◇</sup> Based on 111.6% desorption efficiency

**Conclusion:** Samplers will perform as expected up to their expiration date.

## PACKAGING INTEGRITY STUDY ON 575 SERIES SAMPLERS

**Protocol:** 6 575-001 samplers in unopened Tedlar® pouches were exposed to an atmosphere of 100 ppm n-Hexane (2 X PEL) at 80% relative humidity (25° C) for four hours, and then opened and analyzed.

### Results:

Calculated atmosphere concentration:	103 ppm
Gas sample analysis concentration:	104 ppm (RSD = 8.7%)
Sorbent tube analysis concentration:	103 ppm (RSD = 2.7%)

Sampler analysis: No detectable n-Hexane in any sampler.

(estimated LOD = 1.5 micrograms, equivalent to 0.125 ppm)

**Conclusion:** Packaging will prevent contamination of stored samplers.

## Scope of the Method

<b>Analyte:</b>	Styrene
<b>Matrix:</b>	Air
<b>Procedure:</b>	Adsorption on a 575-002 SKC passive sampler, desorption with 2 ml of CS <sub>2</sub> , and analysis by GC-FID.
<b>Exposure Guidelines:</b>	ACGIH-TLV (1994/95) 50 ppm TWA, 100 ppm STEL OSHA (1995) 50 ppm TWA, 100 ppm STEL NIOSH (1995) 50 ppm TWA, 100 ppm STEL

### Validation Range, Recovery:

<u>Compound</u>	<u>Validation Range ppm in air</u>	<u>Mean % Recovery</u>
Styrene	25-250	> 75%
	5-25	< 75%

**Detection Limits:** Depending on the instrumentation, it is possible to determine at least 13 µg/sampler with a relative standard deviation of less than 10%. This corresponds to an air concentration of 0.5 ppm (v/v) based on an 8 hour sample at the validated sampling rate of 13.7 ml/min.

**Temperature Effects:** Samples could be taken from 10° C to 40° C.

**Factorial:** No significant effects were found due to the interaction of factors that affect sampling accuracy.

**Humidity Effects:** High humidity conditions (80% RH at 25° C) did not affect the recovery of styrene on the 575-002 passive sampler or the uptake rate.

**Storage Effects:** The passive sampler can store for at least 21 days at room temperatures or in a refrigerator with no loss in recovery.

**Interferences:** Any compound that has the same retention time as Styrene will interfere with the analysis. A study was also conducted where passive samplers were exposed to 200 ppm toluene and 100 ppm Styrene and no significant loss in recovery was observed.

**Validation Completion Date:** April 1995

### Physical Properties:

<u>Mol. Weight (g/mole)</u>	<u>Boiling Pt. at 760 mm Hg</u>	<u>Density (g/ml)</u>
104.15	145.2° C	0.9060

# Background

## History of Methodology

Previous methodologies have used activated charcoal SKC Lot 120 in a sample tube, or a newer method which uses sample tube containing charcoal coated with tertiary butyl catechol.

## Research Purpose

The present work was to evaluate and validate the SKC 575 Series passive sampler containing Anasorb 747 as a method for sampling Styrene. The passive sampler was validated over a concentration range of 0.1 to 5 x PEL. Critical parameters such as analytical recovery, concentration, relative humidity, reverse diffusion, storage stability, temperature, sampling time, wind speed and orientation, and the presence of interfering compounds were addressed.

## Experimental

99+% Styrene (Aldrich Chemical Co.) was used. The HPLC-grade carbon disulfide (99.9%) was obtained from Aldrich Chemical Company. The 575 passive sampler containing Anasorb 747 (SKC Cat. No. 575-002) and the Anasorb 747 tubes used for atmosphere calibrations (SKC Cat. No. 226-81A) are available from SKC, Inc.

A dynamic atmosphere generation apparatus was used to generate precise concentrations of Styrene in air for exposure of the passive samplers. The system is described in Appendix A and Figure 1. The atmosphere was fed into an exposure test chamber. The passive samplers were exposed on a rotating bracket inside the test chamber to simulate wind velocity and orientation.

**Analytical recoveries** for the passive samplers were conducted by injecting a known amount of Styrene (as a CS<sub>2</sub> solution) into the back of each sampler. The passive samplers were capped, allowed to equilibrate overnight, and analyzed the next day to determine analytical recovery or desorption efficiency. The tests were conducted at mass loadings equivalent to an 8-hour time weighted average sample (6.48 L at the expected sampling rate of 13.5 ml/min) at 0.1, 0.5, 1.0 and 2.0 PEL under dry conditions. A wet desorption efficiency was conducted by first exposing the passive sampler to 80% RH air for eight hours and then spiking the passive sampler at a mass loading equivalent to the 1 PEL (50 ppm) level. These passive samplers were all equilibrated overnight and analyzed the next day. Analytical recovery was also carried out at 0.01 PEL for low-level work.

**The sampling rate, reverse diffusion and storage stability** experiments on the passive sampler were conducted under dynamic conditions in the test chamber described above. In the storage stability study, recovery is referred back to the reference samples analyzed on Day 1.

The passive samplers were desorbed (in situ) with 2 ml of CS<sub>2</sub> and shaken on a flatbed shaker for 30 minutes. All extracts were transferred to autosampler vials and analyzed by flame ionization gas chromatography. A chromatogram with analytical conditions is shown in Figure 2.

## Sampling Rate Determination

Sampling rates can be determined by one of several statistical methods from the experimental data and they differ by only a small amount. Any bias taken is toward the protection of the worker.

We use the time-weighted average from one to eight hours where results fall within NIOSH criteria.

We constantly review our data and conduct experimental work to provide the most precise sampling rate. This rate may differ slightly from previously published sampling rates. Use the rate listed in this report.

# Analytical Recovery

## NIOSH Requirements

### Experimental Design

Spike 16 samplers, 4 at each of 4 concentration levels (0.1, 0.5, 1.0 & 2.0 x STD) Equilibrate about 12 h and analyze.

### Interpretation of Results

For the 3 higher levels require  $\geq 75\%$  recoveries with  $S_r \leq 0.1$ .

## Results

PEL Level	Spike ( $\mu\text{g}$ )	Recovery ( $\mu\text{g}$ )	Recovery %	Mean	RSD %
0.01	13.39	3.33	24.5	27.0	6.1
		3.82	28.1		
		3.54	26.1		
		3.75	27.6		
0.02	26.65	8.85	39.1	34.8	9.1
		7.34	32.4		
		7.34	32.4		
		8.02	35.4		
0.1	133.9	85.97	64.2	64.7	4.4
		88.91	66.4		
		90.02	67.2		
		81.47	60.8		
0.5	679.5	515.1	75.8	76.4	4.2
		514.1	75.7		
		549.4	80.9		
		498.1	73.3		
1.0	1359.0	1097.0	80.7	83.2	2.2
		1130.0	83.1		
		1155.0	85.0		
		1142.0	84.0		
1.0*	1359.0	1118.0	82.3	85.2	2.6
		1170.0	86.1		
		1190.0	87.6		
		1152.0	84.8		
2.0	2718.0	2722.0	100.1	99.3	0.9
		2708.0	99.6		
		2690.0	99.0		
		2669.0	98.2		

A desorption efficiency curve based on these and other data points has been used to correct the results of the validation experiment.

\* Samplers pre-exposed to 80% humidity.

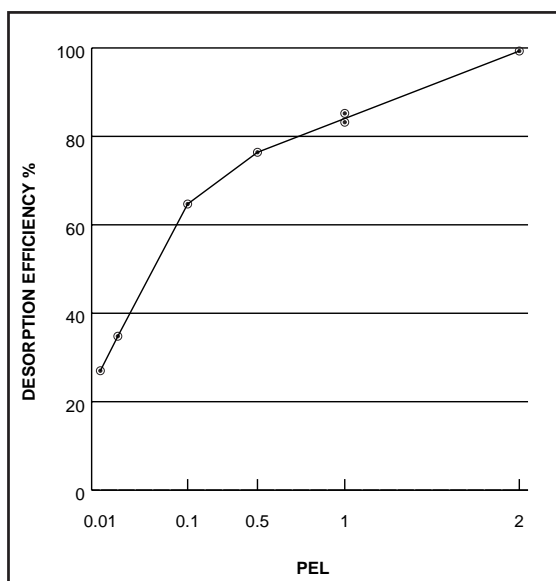

# Sampling Rate and Capacity

## NIOSH Requirements

### Experimental Design

Expose samplers (4 per time period) for 1/8, 1/4, 1/2, 1, 2, 4, 6, 8, 10 and 12 h to 2 x STD, 80% RH and 20 cm/s face velocity. Plot concentration vs. time exposed. Determine MRST and SRST.

### Interpretation of Results

Verify sampling rate. State useful range at 80% RH and 2 x STD. Capacity - sample loading corresponding to the downward break in conc. vs time curve from constant concentration. SRST-time linear uptake rate achieved. MRST - 0.67 x capacity (1 analyte)  
MRST-0.33 x capacity (Multi-analyte)

## Results

Time (hrs)	Uptake (µg)	Mean (µg)	RSD%	DE Corr (µg)	Concn. (ppm)
0.125	26.4	25.6	4.1	48.6	113.6
	24.5				
	25.3				
0.25	26.8	48.3	3.2	86.2	100.7
	48.9				
	48.3				
0.5	49.7	131.0	1.6	201.5	117.7
	46.1				
	132.3				
1	128.1	248.5	2.4	360.1	105.2
	132.7				
	130.7				
2	247.3	520.1	10.9	684.4	100.0
	253.9				
	252.3				
4	240.4	1172	1.5	1465	107.0
	481.0				
	520.6				
6	479.0	1718	2.4	2021	98.4
	599.8				
	1156				
8	1185	2449	4.3	2721	99.4
	1190				
	1158				
10	1732	3140	4.0	3306	96.6
	1697				
	1673				
12	1769	3799	2.8	3999	97.3
	2502				
	2468				

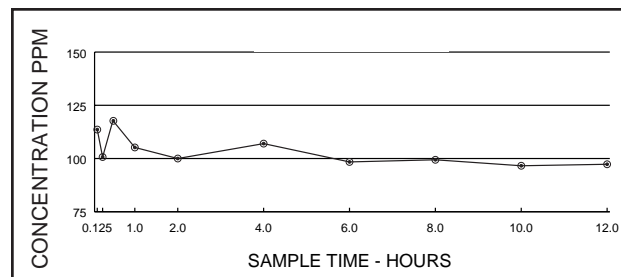
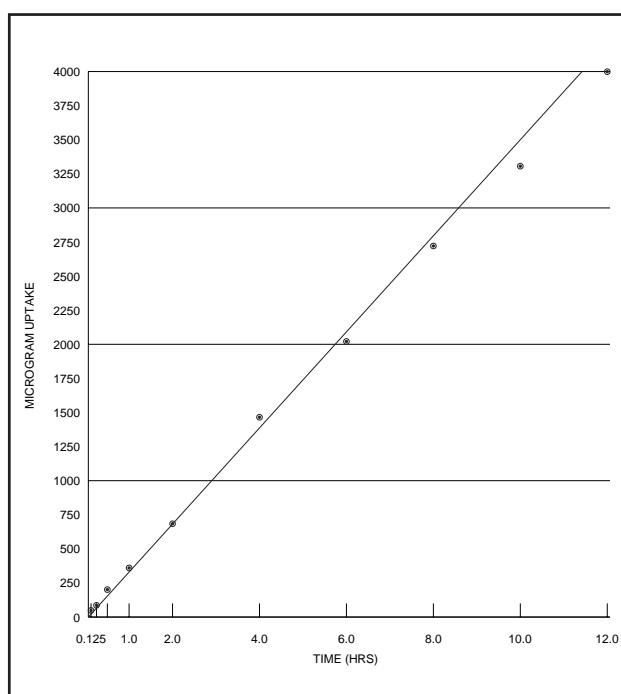

Concentration values are calculated using the 1 through 8 hour time-weighted average sampling rate of 13.7 ml/min based on a standard atmosphere of 98.7 ppm (calculated, checked by two reference methods).

# Reverse Diffusion

## NIOSH Requirements

### Experimental Design

Expose 20 samplers to 2 x STD 80% RH for 0.5 x MRST. Remove and analyze 10 samplers. Expose others to 80% RH and no analyte for remainder of MRST.

### Interpretation of Results

Require  $\leq 10\%$  difference between means of the two sampler sets at the 95% CL.

---

---

### Results (in micrograms)

#### Exposed 4 hours to analyte

Uptake ( $\mu\text{g}$ )	DE Corr ( $\mu\text{g}$ )
2596	2732
2720	2863
2881	3033
2789	2936
<b>Mean:</b>	<b>2891</b>
<b>SD:</b>	<b>126.8</b>
<b>RSD:</b>	<b>4.4%</b>

#### Exposed 4 hours to analyte plus 4 hours at zero analyte concentration

Uptake ( $\mu\text{g}$ )	DE Corr. ( $\mu\text{g}$ )
2520	2651
2601	2739
2518	2650
2861	3011
<b>Mean:</b>	<b>2763</b>
<b>SD:</b>	<b>170.7</b>
<b>RSD:</b>	<b>6.2%</b>

**The difference between the two sets of results is less than 10%.**

Results normalized to 240 minutes from 243 minutes.

Study carried out at 4 x PEL (205.7 ppm) as a more rigorous test.

# Storage Stability

NIOSH Requirements

## Experimental Design

Expose 3 sets of samplers (10 per set) at 80% RH, 1 x STD, and 0.5 x MRST. Analyze first set within 1 day, second set after 2 weeks storage at about 25° C, third set after 2 weeks storage at about 5° C.

## Interpretation of Results

Require  $\leq 10\%$  difference at the 95% CL between means of stored sampler sets and set analyzed within 1 day.

## Results (in micrograms)

	Room Temp		Refrigerator	
	<u>Uptake</u>	<u>DE Corr.</u>	<u>Uptake</u>	<u>DE Corr</u>
Day 1 for Day 7 (52.8 ppm)	596.9	775.2	-----,*	-----,*
Day 1 for Day 14 (54.6 ppm)	596.7	775.0	495.5	643.4
Day 1 for Day 21 (52.4 ppm)	617.2	801.6	638.0	828.6
Day 7	640.0	831.2	582.2	756.1
	634.5	824.0	633.1	822.2
	604.9	785.6	639.3	830.3
Day 14	597.8	776.4	548.5	712.4
	606.6	787.8	486.5	631.9
	574.5	746.0	535.1	694.9
Day 21	580.8	754.3	576.5	748.7
	598.5	777.3	564.5	733.1
	607.1	788.4	602.0	781.9
<b>Mean:</b>		<b>785.7</b>		<b>745.7</b>
<b>Day 7 - 21</b>				
<b>SD:</b>		<b>28.0</b>		<b>62.4</b>
<b>RSD:</b>		<b>3.6%</b>		<b>8.4%</b>

**There is no significant loss of sample on storage.**

Experiment altered to track storage closely and to extend storage to 21 days.

Day 14 results normalized to 240 minutes from 250 minutes.

\* Sampler lost

# Factorial Results

## NIOSH Requirements

### Experimental Design

Test the following factors at the levels shown. Use a 16 run fractional factorial design (4 samplers per exposure) to determine significant factors.

<u>Factor</u>	<u>Test Levels</u>
analyte concentration	0.1 & 2 x STD
exposure time	SRST & MRST
face velocity	10 & 150 cm/s
relative humidity	10 & 80% RH
interferant	0 & 1 x STD
sampler orientation	parallel & perpendicular (to air flow)

### Interpretation of Results

Indicate any factor that causes a statistically significant difference in recovery at the 95% CL. Investigate further to characterize its effect.

---



---

## Results

(All results in micrograms per ppm per minute).

<u>Run #</u>	<u>Individual Monitor Results</u>				<u>Average</u>	<u>%RSD</u>
1	4.2657	4.3347	4.4625	4.3844	4.3618	1.9
2	3.9398	3.6974	3.8439	3.7673	3.8121	2.7
3	3.5347	3.4281	3.3956	4.2333	3.6479	10.8
4	3.7680	3.6070	3.7075	3.6142	3.6742	2.1
5	3.6714	3.7906	3.9249	3.7170	3.7760	2.9
6	2.7901	2.7653	2.8045	2.6827	2.7607	2.0
7	3.6128	3.7474	4.2029	3.8302	3.8483	6.6
8	3.2713	3.8999	3.7237	3.8000	3.7862	2.2
9	3.3627	3.4588	3.5652	3.5348	3.4804	2.6
10	3.4654	3.4428	3.5358	3.5307	3.4937	1.3
11	3.2952	3.3165	3.2946	3.3711	3.3194	1.1
12	4.5342	4.1825	4.5152	4.5532	4.4463	4.0
13	4.0796	4.0782	4.4595	4.2021	4.2049	4.3
14	2.9608	2.9182	2.9419	3.0175	2.9596	1.4
15	4.0426	3.6643	3.8289	3.8797	3.8539	4.0
16	3.8732	3.3903	4.0443	3.6519	3.7399	7.6

Notes: Low face velocity = 20 cm/sec  
 Low concentration = 0.1 PEL  
 Minimum sample time = 2 hours

200 ppm Toluene used in the interference experiments.



## Factorial Summary

<u>Run Number</u>	<u>µg/ppm/hour</u>
Run# 1	= 4.3618
Run# 2	= 3.8121
Run# 3	= 3.6479
Run# 4	= 3.6742
Run# 5	= 3.7760
Run# 6	= 2.7607
Run# 7	= 3.8483
Run# 8	= 3.7862
Run# 9	= 3.4804
Run# 10	= 3.4937
Run# 11	= 3.3194
Run# 12	= 4.4463
Run# 13	= 4.2049
Run# 14	= 2.9596
Run# 15	= 3.8539
Run# 16	= 3.7399
<b>Average</b>	<b>= 3.6978 = 14.5 ml/min</b>

<u>Factor</u>	<u>Effect</u>	<u>Percent</u>	<u>Significance</u>
A - Concentration	-0.17	4.7%	N.S.
B - Relative Humidity	-0.12	3.3%	N.S.
C - Interferants	-0.17	4.5%	N.S.
D - Time	-0.09	2.4%	N.S.
E - Face Velocity	0.24	6.6%	N.S.
F - Orientation	0.29	7.8%	N.S.
E1 - ABC	0.04	1.2%	N.S.
E2 - ABD	0.02	0.6%	N.S.
E3 - AB + EF	0.47	12.8%	N.S.
E4 - AC + DF	-0.38	10.3%	N.S.
E5 - AD + CF	0.18	5.0%	N.S.
E6 - AE + BF	-0.16	4.4%	N.S.
E7 - CD + BE	0.05	1.3%	N.S.
E8 - BC + DE	0.20	5.4%	N.S.
E9 - BD + CE	-0.23	6.2%	N.S.

**Minimum Significant Effect (MSE) = ± 0.55**  
**No significant effect of factors or their interactions.**

# Temperature Effects

NIOSH Requirements

## Experimental Design

Expose samplers (10 per temp) to 0.5 x STD at 10, 25, & 40° C for 0.5 x MRST.

## Interpretation of Results

Define temperature effect and verify correction factor, if provided.

## Results (in micrograms)

40° C @ 0.5 x PEL		40° C @ 5 x PEL	
Sample ( $\mu\text{g}$ )	DE Corr. ( $\mu\text{g}$ )	Sample ( $\mu\text{g}$ )	DE Corr ( $\mu\text{g}$ )
277.1	379.6	3150	3315
292.3	400.4	2885	3037
277.9	380.7	3115	3279
282.1	386.4	2975	3131
272.8	386.4	3083	3245
282.8	373.7	3334	3510
269.4	369.0	3140	3306
266.6	365.2	-----*	-----*
290.1	397.4	3110	3273
282.5	387.0	3296	3470
<b>Mean:</b>	<b>382.0</b>		<b>3285</b>
<b>RSD:</b>	<b>3.0%</b>		<b>4.5%</b>
<b>Concentration<sup>1</sup>:</b>	<b>25.8</b>		<b>254</b>
<b>Uptake<sup>2</sup>:</b>	<b>3.702</b>		<b>3.233</b>
<b>Theoretical:</b>	<b>3.589</b>		<b>3.589</b>

**Uptake is within 10% of theoretical for both low and high concentrations.**

Experiment performed at 5 x PEL for more rigorous test.

\* Sampler lost

<sup>1</sup> In ppm at the sampling temperature.

<sup>2</sup> Uptake rate measured as micrograms/ppm (sampling temperature)/hour.

# Accuracy and Precision

## NIOSH Requirements

### Experimental Design

Calculate precision and bias for samplers (10 per conc. level) exposed to 0.1, 0.5, 1 & 2 x STD at 80% RH for ≥ MRST. Use data from previous experiments.

### Interpretation of Results

Requires bias within ± 25% of true value at 95% CL with precision  $S_r \leq 10.5\%$  for 0.5, 1 & 2 x STD levels.

## All Values in µg/ppm/hr

### Samplers run at 5.0 x PEL

Values for individual monitors for the Temperature Effects Experiment

3.1812	2.9144	3.1467	3.0047	3.1141
3.3684	3.1726	3.1409	3.3230	

### Samplers run at 4.0 x PEL

Values for individual monitors for the Reverse Diffusion Experiment

3.3204	3.4796	3.6862	3.5683
3.2219	3.3289	3.2207	3.6595

### Samplers run at 2.0 X PEL

Values for individual monitors for the Rate/Capacity Experiment

4 Hour -	3.6601	3.7519	3.7677	3.6664
6 Hour -	3.4408	3.3713	3.3236	3.5143
8 Hour -	3.5208	3.4729	3.5616	3.2309

Values for individual monitors for the Factorial Experiment

Run #2 -	3.9398	3.6974	3.8439	3.7673
Run #4 -	3.7680	3.6070	3.7075	3.6142
Run #13 -	4.0796	4.0782	4.4595	4.2021
Run #15 -	4.0426	3.6643	3.8289	3.8797

### Samplers run at 1.0 x PEL

Values for individual monitors for the Storage Stability Experiment

Day 7 -	3.6704	3.9356	3.9015	3.7197
		3.5800	3.8930	3.9313
Day 14 -	3.5485	3.5549	3.6071	3.4158
		2.9460	3.2619	2.8933
Day 21 -	3.8244	3.5988	3.7085	3.7615
		3.9532	3.5720	3.4976

### Samplers run at 0.5 x PEL

Values for individual monitors for the Temperature Effects Experiment

	3.5863	3.7828	3.5968	3.6506	3.5306
	3.6601	3.4862	3.4503	3.7692	3.6563

### Samplers run at 0.1 x PEL

Values for individual monitors for the Factorial Experiment

Run #1 -	4.2657	4.3347	4.4625	4.3844
Run #3 -	3.5347	3.4281	3.3956	4.2333
Run #14 -	2.9608	2.9182	2.9419	3.0175
Run #16 -	3.8732	3.3903	4.0443	3.6519

## Summary

<u>PEL</u>	<u>Relative Standard Deviation</u>	<u>Degrees of Freedom</u>
0.1	6.7%	12
0.5	3.0%	9
1.0	5.5%	20
2.0	3.3%	21
4.0	5.5%	7
5.0	4.4%	8

## Average Values in µg/ppm/hr

<u>Experiment</u>	<u>Average</u>	<u>RSD</u>
Rate/Capacity	3.5235	2.9%
Factorial, 2 PEL	3.8863	3.5%
Storage Stability	3.6038	5.5%
Temperature 0.5 PEL	3.6169	3.0%
Temperature 5.0 PEL	3.1518	4.4%
Reverse diffusion, 4.0 PEL	3.4357	5.5%
Factorial 0.1 PEL	3.6773	6.7%
<b>Overall average</b>	<b>3.5892</b>	<b>4.9%</b>
<b>Overall sampling rate = 14.0 ml/min ± 1.4 ml/min</b>		

Publication No. 1313 Rev 0510  
Styrene (002)

## Appendix A

# Atmosphere Generation Apparatus

The instrument is designed to expose a known concentration of a chemical hazard to a passive sampler under controlled conditions of: 1. Concentration, 2. Temperature, 3. Humidity, 4. Wind Velocity Effect, 5. Time, and 6. Up to four multicomponent hazards.

### Description

The instrument consists of:

1. an exposure chamber in which the wind velocity effects are controlled by internal rotating holders,
2. an air supply and purification train such that dry air is blended with saturated air under desired temperature conditions so as to provide air at a known flow and selectable humidity,
3. an injection system composed of precision motor driven syringes in which 1 to 4 chemical hazards can be injected into the flow system and in which the temperature of the injectors is closely controlled,
4. an electrical control system that controls the entire instrument operation,
5. the chamber concentration can be verified by either solid sorbent sampling tubes actively sampled or by gas analysis of the gas phase. The particular verification method used will depend on the analyte of interest.

Means are also included to check the relative humidity.

**Figure 1**  
**Atmosphere Generation Apparatus**

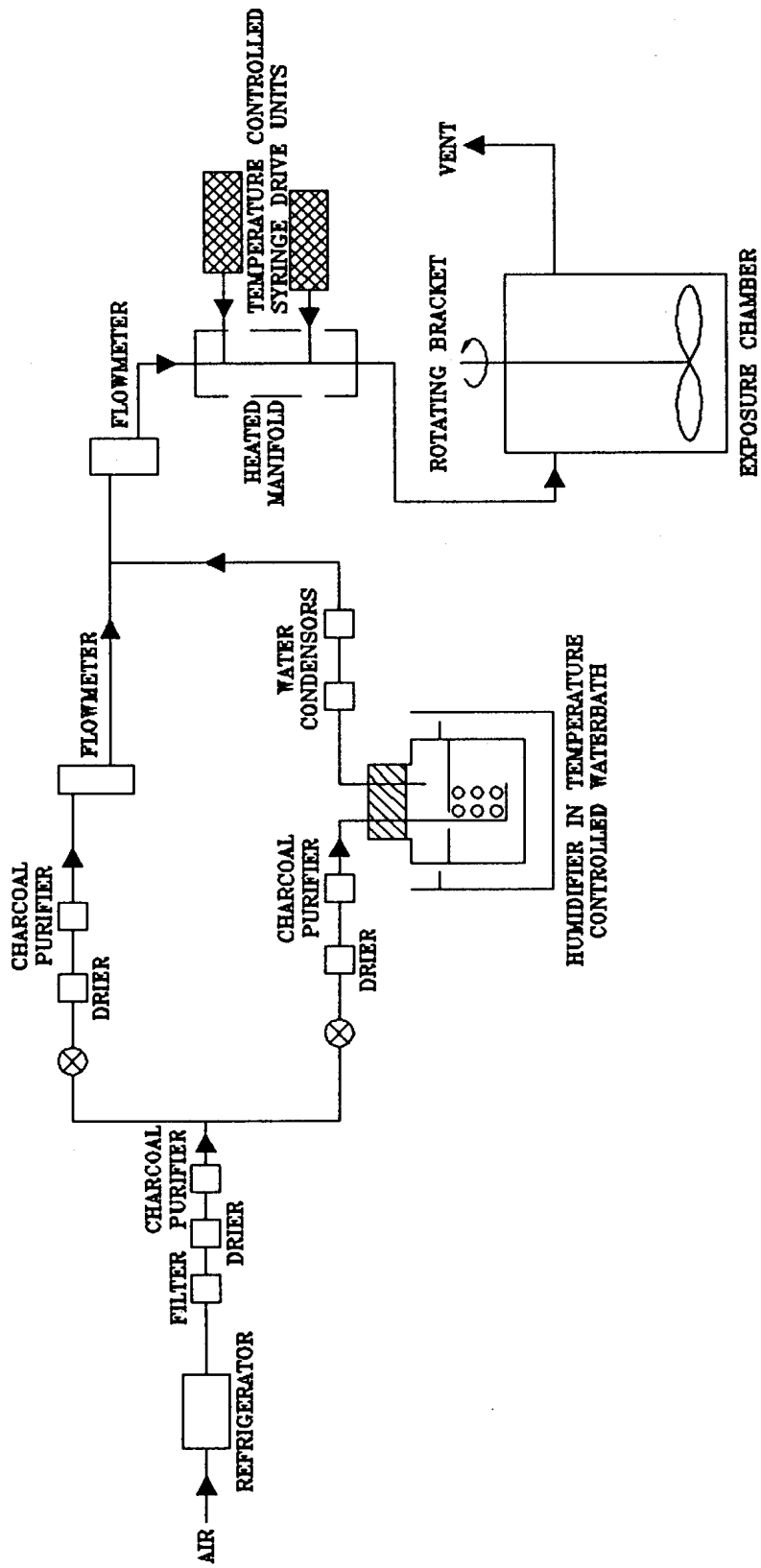

**Figure 2**  
**Analytical Instrument**

**Sample Chromatogram**  
**Styrene in CS<sub>2</sub>**

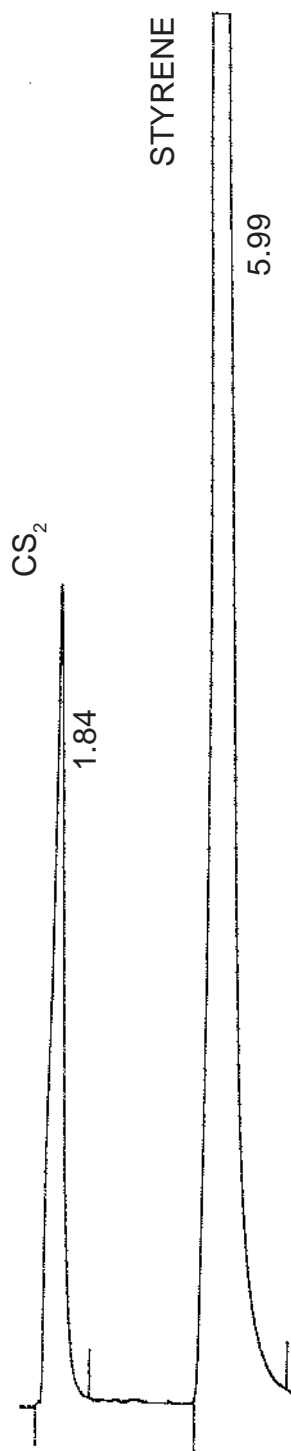

**GC Conditions**

**Column:** 10 ft x 1/8" 10% SP-1000  
on 100/120 mesh  
Chromosorb AW

**Temperatures:** Column 130° C  
FID 150° C

**Carrier Gas:** N<sub>2</sub>

**Injection:** 1.75 µL

## Abbreviations

C	Celsius
CL	confidence level
cm	centimeter
ml	milliliter
min	minute
g	gram
GC-FID	gas chromatography - flame ionization detector
h	hour
L	liter
LOD	limit of detection
MRST	maximum recommended sampling time
N.S.	not significant
PEL	permissible exposure limit
RH	relative humidity
TLV	threshold limit value
TWA	time-weighted average
RSD	relative standard deviation
SD	standard deviation
SRST	shortest recommended sampling time
STD	the appropriate exposure standard (OSHA PEL, ACGIH TVA , or NIOSH recommended standard)
S	second
$S_r$	Pooled relative standard deviation
V	volume

## Trademarks

Anasorb is a registered trademark of SKC Inc.

Chromosorb is a registered trademark of Manville Corp.

Tedlar is a registered trademark of DuPont Corporation.

Porapak is a registered trademark of Waters Associates, Inc.

## References

1. Cassinelli, M.E., Hull, R.D., Crable, J.V. and Teass, A.W., "Diffusive Sampling: An Alternative to Workplace Air Monitoring," A. Berlin, R.H. Brown and K.J. Saunders (Royal Society of Chemistry, London) (eds.), NIOSH Protocol for the Evaluation of Passive Monitors, 1987: p 190-202.
2. Brown, R.H., Harvey, R.P., Purnell, C.J., and Saunders, K.J., "A Diffusive Sampler Evaluation Protocol." *Am. Ind. Hyg. Assoc. J.* 45:67-75 (1984).
3. CEN/TC137/WG2 (1993) EN 482. Workplace Atmospheres - General Requirements for the Performance of Procedures for the Measurement of Chemical Agents. Comité Européen de Normalisation, Brussels, Belgium.
4. CEN/TC137/WG2 (1995) prEN 838. Workplace Atmospheres - Diffusive Samplers for the Determination of Gases and Vapours - Requirements and Test Methods. Comité Européen de Normalisation, Brussels, Belgium.
5. Guild, L.V., Myrmel, K.H., Myers, G. and Dietrich, D.F., "Bi-Level Passive Monitor Validation: A Reliable Way of Assuring Sampling Accuracy for a Larger Number of Related Chemical Hazards," *Appl Occup Environ Hyg*, Vol 7, No. 5, May 1992, pp. 310-317.
6. Harper, M., Fiore, A.A., Fiorito, D.L. and O'Lear, C., "Comparison of the Tests for Non-ideal Behaviour by Reverse Diffusion in the NIOSH and CEN Diffusive Sampler Evaluation Protocols," Submitted to *Ann. Occup. Hyg.* (1995).
7. Harper, M., Guild, L.V., "Levels of Validation - Experience in the Use of the NIOSH Diffusive Sampler Evaluation Protocol," Submitted to *Am. Ind. Hyg. Assoc. J.* (1995).



# **Validation of Styrene using SKC Passive Sampler 575-002**

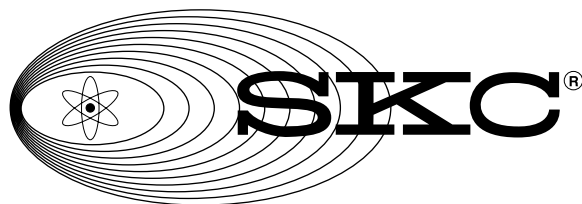

**SKC Inc.  
863 Valley View Road  
Eighty Four, PA 15330**

# Contents

Abstract.....	1
Importance of Validation of Passive Samplers.....	2
Summary of NIOSH Validation Protocol.....	4
Bi-Level Validation.....	6
Comments on the Relationship Between the NIOSH and CEN Diffusive Sampler Evaluation Protocols.....	8
Scope of the Method.....	10
Background.....	11
Analytical Recovery.....	12
Sampling Rate and Capacity.....	13
Reverse Diffusion.....	14
Storage Stability.....	15
Factorial Results.....	16
Factorial Summary.....	17
Temperature Effects.....	18
Accuracy and Precision.....	19
Appendix A. Atmosphere Generation Apparatus.....	20
Figure 1. Atmosphere Generation Apparatus.....	21
Figure 2. Analytical Instrument.....	22
Abbreviations, Trademarks.....	23
References.....	24